

**OPERATION**

TO CHANGE FROM 12v TO 24v YOU NEED TO PRESS THE MOMENTARY SWITCH IN ONE DIRECTION TO LATCH THE SYSTEM INTO 24v MODE. THE 24v LED INDICATOR WILL THEN ILUMINATE

TO CHANGE BACK TO 12v PRESS THE MOMENTARY SWITCH IN THE OTHER DIRECTION TO DE-LATCH THE SYSTEM AND RETURN IT TO 12v. THE 24v LED INDICATOR WILL THEN GO OFF

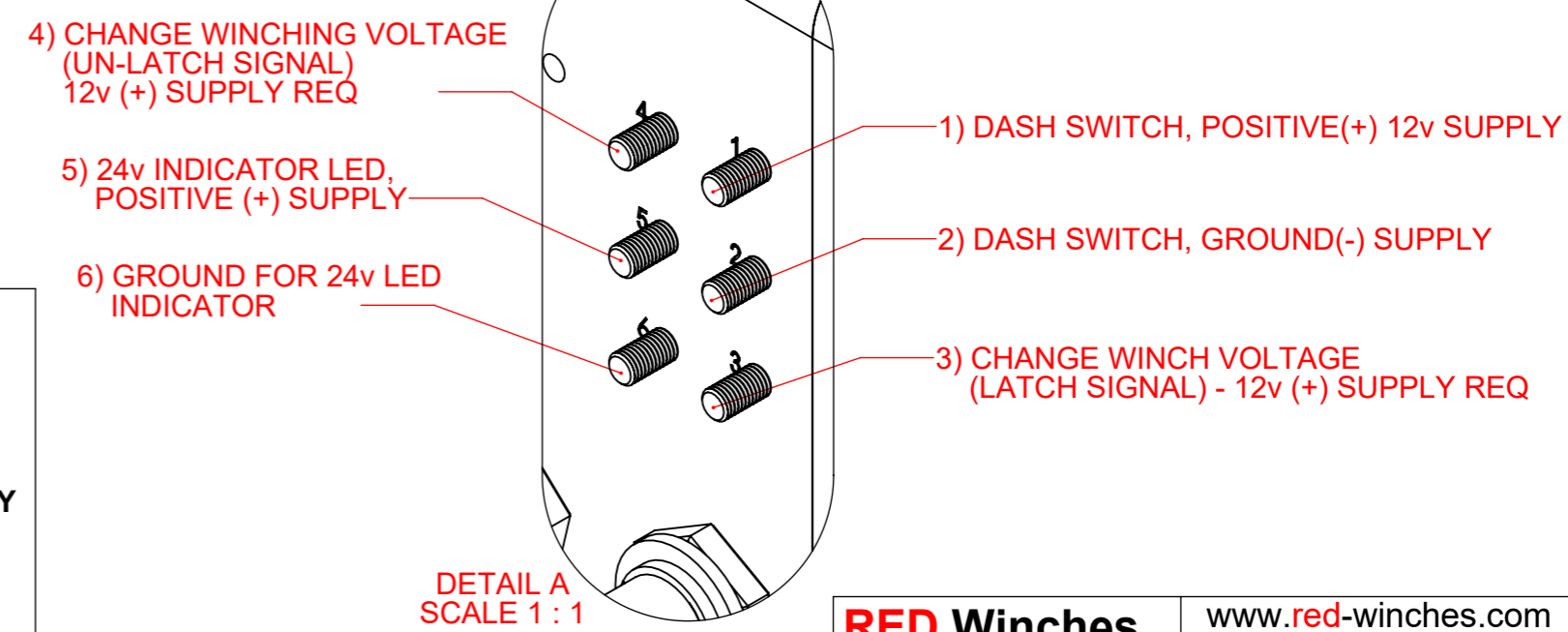

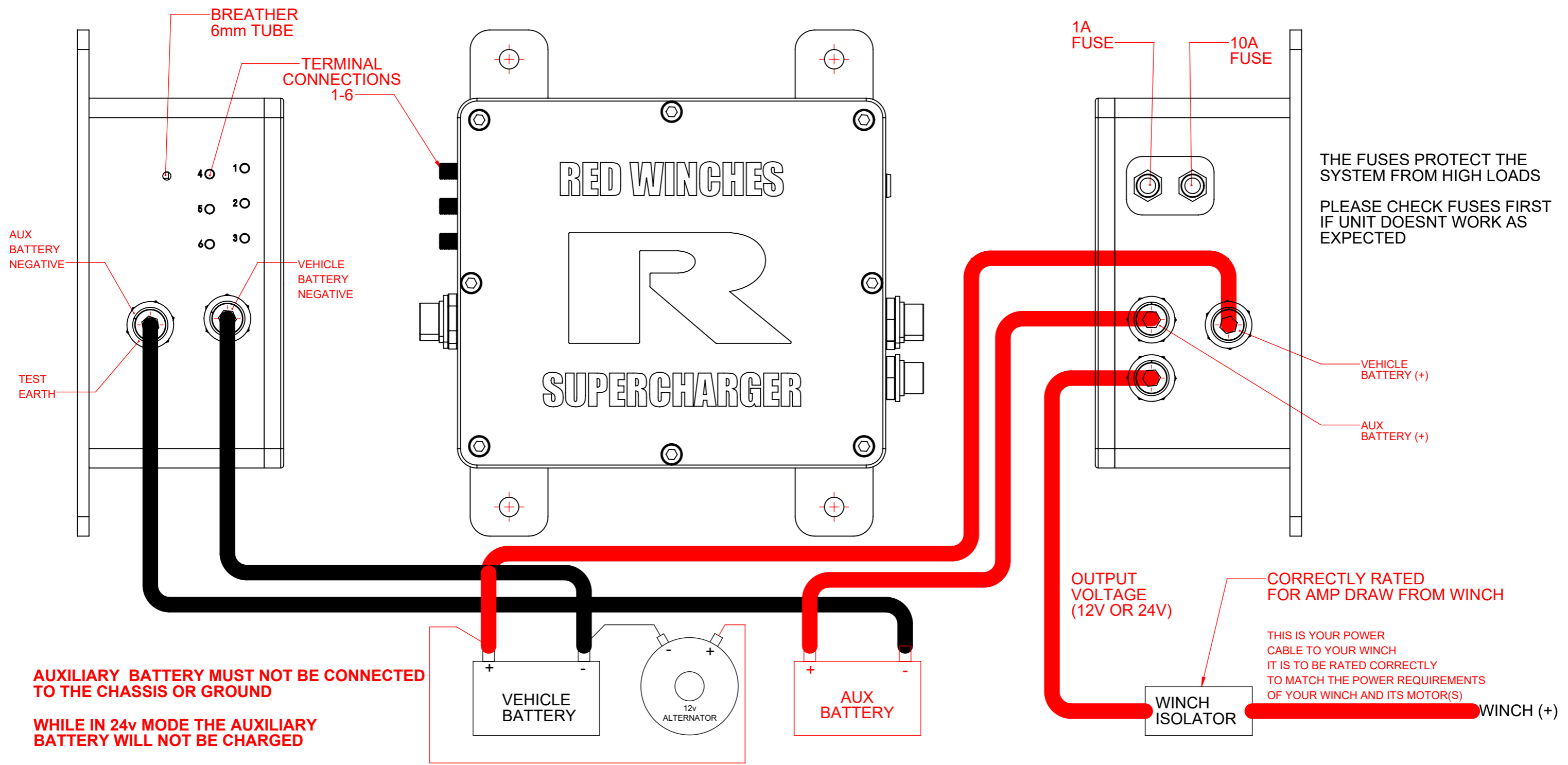

Part No. 741-0820

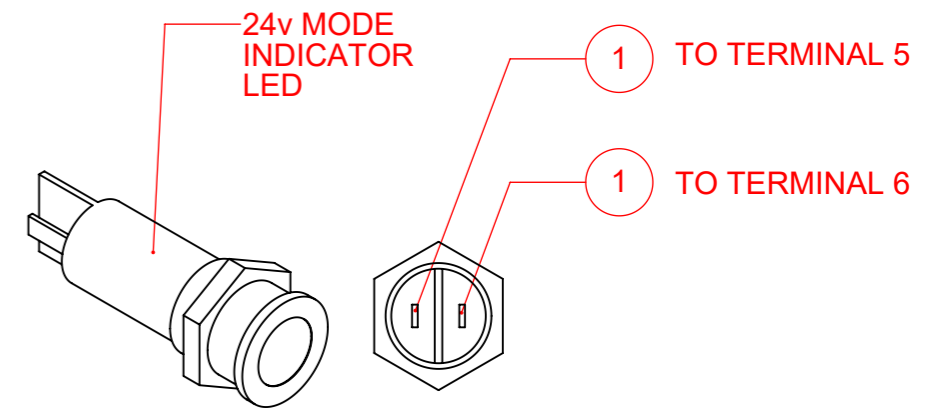
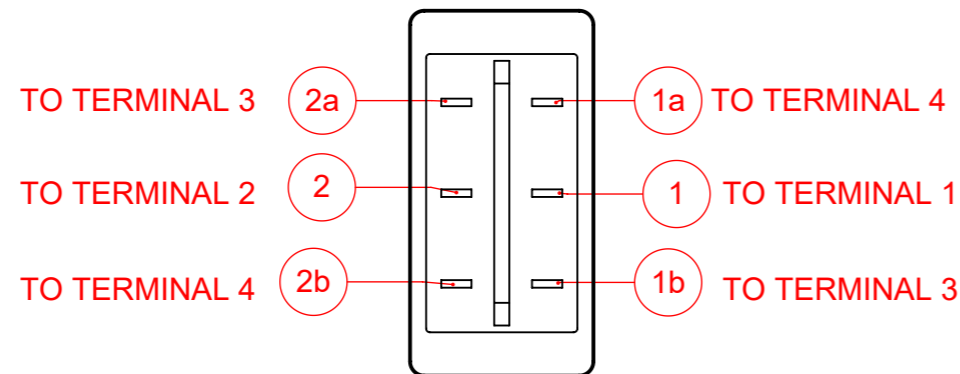

**RED Winches**      [www.red-winches.com](http://www.red-winches.com)  
 ULTIMATE PERFORMANCE PRODUCTS

**TITLE**      **RED WINCHES - SUPERCHARGER UNIT**  
**GIVES THE ABILITY TO RUN 24V AN 12V FROM YOUR 12V SYSTEM ON YOUR TRUCK**

Telephone: +44 (0)1460 297 355  
 Email: sales@red-winches.com

DRAWING NUMBER: **SUPERCHARGER MANUAL**      SCALE: **1:2**      SHT 2 OF 2

Drawing not to be reproduced or distributed in any format or method without specific permission from Redstart/Design.