



COBRA 2
HIGH MOUNT | ELECTRIC WINCH

COBRA 2
USER MANUAL





CONTENTS

About	p3
Safety	p5
Winch Dimensions	p8
Winch Overview Diagram	p10
Winch Exploded Diagrams	p11
Winch Pulley Arrangement	p13
Winch Freespool Diagram	p14
Wiring Connection Schematic	p15
Ox Motor Diagram	p16
Standard Gear Box Diagram	p17
General Winch Maintenance	p18
Winch Operation	p19

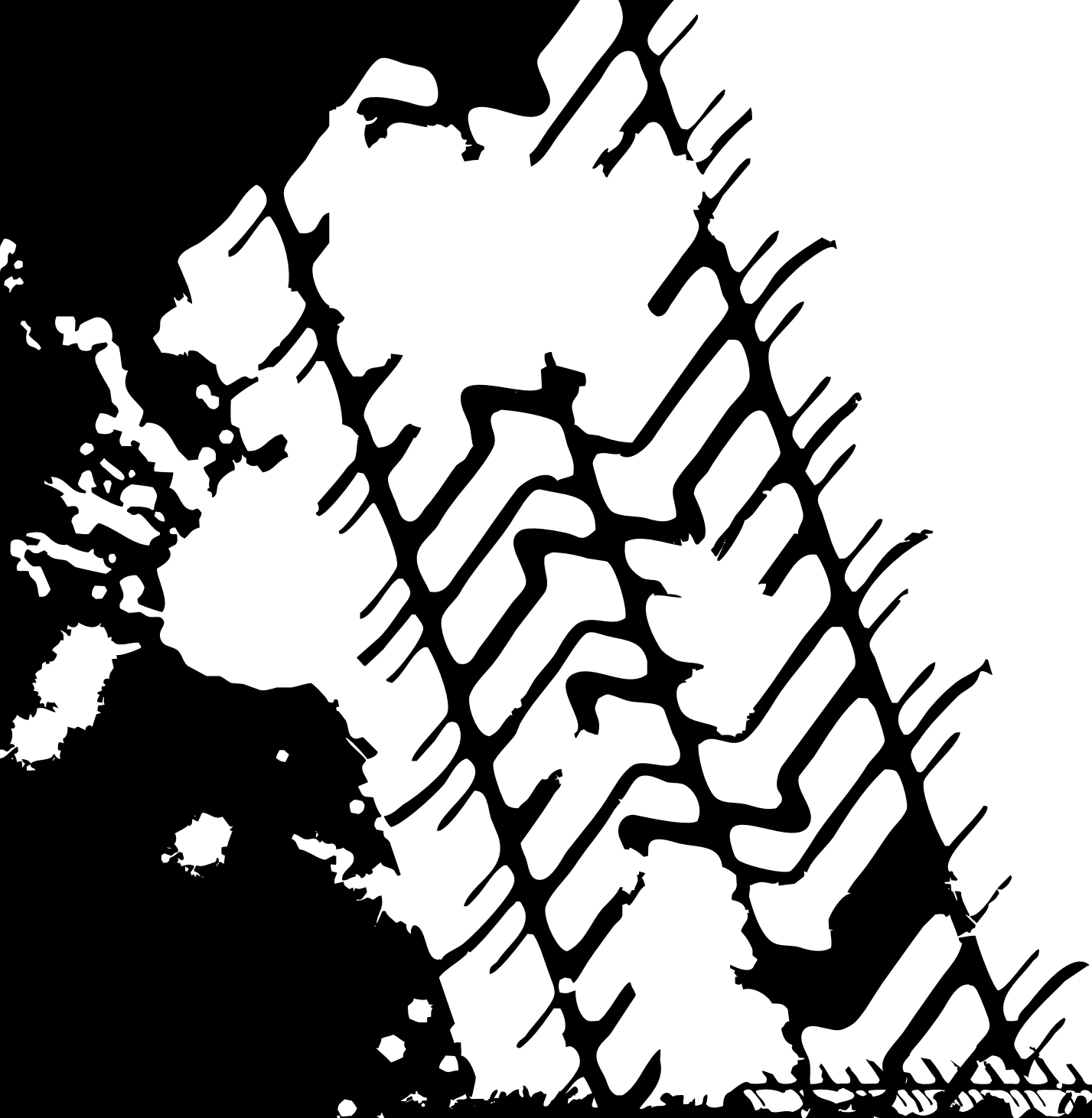

COBRA 2

HIGH MOUNT | ELECTRIC WINCH

- > High Mount (Motor) Style Winch
- > Single motor
- > 12v / 24v dc
- > Air brake fitted on all models
- > Freespool (Option of Manual or Air Operated)
- > Standard and XL Drum lengths available
- > Gearboxes Available: Standard, Adventure, Overdrive
- > Rated pulls: From 2,000kg - 6,000kg (*model specific*)
- > Ox motor fitted on all options for the ultimate power behind your winching

This winch is a RED Winches designed product, whose designs have undergone extensive testing. The end user can now enjoy a professional highly engineered, precision, high performance electric winch capable of operating in the most demanding of situations. The small compact size combined with its pulling power and solid billet machined cnc housings make it an ideal winch for maximum impact when faced with minimal installation space.

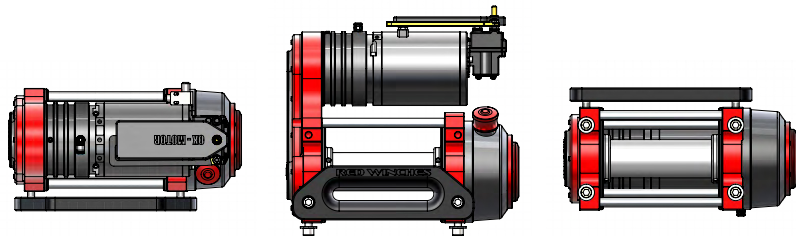

COBRA 2

> The Cobra2 Winch

The Cobra2 is an excellent choice when it comes to speed and power for electric winching.

It has been designed specifically for high performance and durability. The winch can give you great speeds combine with strong pulling power giving you the end user options for your recovery needs, so you have power and speed when you need it.

The winch body is CNC machined from solid high grade heat treated aerospace aluminium. Its brake system offers something previously unavailable on a winch and ensures the winch stops instantly when your finger is taken off the winch control button.

> RED Winch Air Brake System

Springs apply pressure to a steel disc which then applies pressure to the brake disc and its material when the winch is not in use. This applies the brake and stops the winch drum from moving under load and from spooling out the rope.

An air solenoid for the air brake is fitted next to the motors at the top of the winch. This is fed by an air supply from the on-board compressor.

When you winch in or out you energise your motor solenoid, this also energises the air solenoid valve for the brake on top of the winch. This then allows air to go into a specially designed chamber that releases the

brake instantly.

When you remove your winching finger from the controls the air solenoid dumps the air and the springs apply the brake disc onto the brake pads.

This means compared to normal winching you do not get overrun of excess rope causing snatching and jerking as the vehicle takes up the slack rope that has been spooled out. It also means when spooling the rope back onto the drum and you stop winching, the rope stops and doesn't continue spooling in. A safety feature many find important when looking after the operators hands.

The high power Albright motor solenoid is used to switch direction of the motor and at the same time provide a feed to the 12v brake system via their signal terminals.

> Gearbox

The gearbox has been specifically designed for strength, power and ease of service.

The gears are manufactured from chromium molybdenum steel and case hardened to give maximum strength (Up to 1230 N/mm²) and excellent durability.

The gearbox runs in grease not oil making it much easier to service in the field.

> Quick Start Guide

- 1 Check winch connections are correctly fitted and are not loose
- 2 Switch winch isolator on
- 3 Switch Compressor on
- 4 Connect Wireless Controller with base unit (if used)
- 5 Winch is now ready to be used



SAFETY GUIDELINES

Every winching / recovery situation has the potential for personal injury. In order to minimize that risk, it is important to read this guide carefully before using the winch.

Please familiarize yourself with the operation of your winch before using it and be constantly safety oriented. In this guide we provide important safety information









and instructions on how to install your winch.



SAVE THIS MANUAL and other product literature found in this kit for future reference and review frequently for continuing safe operation.

Instruct all users of this winch product to review this manual before operating the winch.

> Symbol Index for winch

SYMBOL	EXPLANATION
	Read all product literature
	Always wear leather gloves
	Always wear hearing & eye protection
	Fairlead pinch point
	Always use supplied hook strap
	Properly seat load in throat hook
	Never apply load to hook tip or latch
	Never hook back on rope

SYMBOL	EXPLANATION
	Explosion/Bursting Hazard
	Fire and burn hazard
	Never route electrical cables across sharp edges
	Never route electrical cables through or near moving parts
	Avoid installing electrical cables around pinch and wear/abrasion points
	Never use winch as a hoist
	Do not move people
	Wind rope on bottom of drum

SYMBOL	EXPLANATION
	Never wind rope over top drum
	Hand piercing/cutting hazard
	Hot surface hazard
	Finger/Fairlead crushing Hazard
	Exposed wiring hazard insulate exposed wiring and terminals
	Clutch disengaged
	Avoid side pulls
	Never hook the wire rope back onto itself



> Warnings and Cautions

As you read these instructions, you will see **WARNINGS**, **CAUTIONS**, **NOTICES** and **NOTES**.

Each message has a specific Purpose. **WARNINGS** are safety messages that indicate a potentially hazardous situation, which, if not avoided could result in serious injury or death. **CAUTIONS** are safety messages that indicate a potentially hazardous situation, which, if not avoided, could result in minor or moderate injury. A **CAUTION** may also be used to alert against unsafe practice. **CAUTIONS** and **WARNINGS** identify the hazard, indicate how to avoid the hazard, and advise of the probable consequence of not avoiding the hazard. **NOTICES** are messages to avoid property damage. **NOTES** are additional information to help you complete a procedure. **PLEASE WORK SAFELY!**

> EMC Regulation

This device complies EMC regulations. Operation is subject to the following two conditions:

- This device may not cause harmful interference.
- This device must accept any interference received, including interference that may cause undesired operation.

This equipment has been tested and found to comply. See separate CE certificate. These approvals are designed to provide reasonable protection against harmful interference in a residential installation. This equipment generates, uses and can radiate radio frequency energy, and if not installed and used in accordance with the instructions, may cause harmful interference to radio communications. However, there is no guarantee that interference will not occur in a particular installation. If this equipment does cause harmful interference to radio or television reception, which can be determined by turning the equipment off and on, the user is encouraged to try to correct the interference by one or more of the following measures:

- Reorient or relocate the receiving antenna (if installed)
- Increase the separation between the equipment and receiver.
- Connect the equipment into an outlet on a circuit different from that to which the receiver is connected.
- Consult the dealer or an experienced radio/TV technician for help.

> WARNING



> Moving Parts Entanglement Hazard

Failure to observe these instructions could lead to serious injury or death.

Winching Safety:

- **Always** Know Your Winch. Take time to fully read the Instructions in Order to understand your winch and its operations.
- **Never** exceed winch or winch rope rated capacity. Double line using a snatch block to reduce winch load.
- **Always** wear heavy leather or approved gloves when handling winch rope.
- **Never** use winch or winch rope for towing. Shock loads can damage, overload and break rope.
- **Never** use a winch to secure a load.
- **Never** operate this winch when under the influence of drugs, alcohol or medication
- **Never** operate this winch if you are under 16 years of age.

Installation Safety:

- **Always** choose a mounting location that is sufficiently strong to withstand the maximum pulling capacity of your winch.
- **Always** use class 8.8 metric(grade 5) or better fasteners
- **Never** weld mounting bolts.
- **Always** use factory approved mounting hardware, components, and accessories.
- **Never** use bolts that are too long.
- **Always** confirm required bolt length to ensure proper thread engagement.
- **Always** complete the winch installation and hook attachment before installing the wiring.
- **Always** keep hands clear of winch rope, hook loop, hook and fairlead opening during installation, operation, and when spooling in or out.
- **Always** position fairlead slot so rope does not rub on it during normal straight line recovery operations.
- **Always** prestretch rope and respool under load before use. Tightly wound rope reduces chances of 'binding', which can damage the rope.

> WARNING



> Moving Parts Entanglement Hazard

Failure to observe these instructions could lead to serious injury or death.

General Safety:

- **Always** inspect winch rope, hook, and slings before operating winch. Frayed, kinked or damaged winch rope must be replaced immediately. Damaged components must be replaced before operation. Protect parts from damage.
- **Always** remove any element or obstacle that may interfere with safe operation of the winch.
- **Always** be certain the anchor you select will withstand the load and the strap or chain will not slip.
- **Always** use supplied hook or spliced loop whenever spooling winch rope in or out, during installation and during operation.
- **Always** require operators and bystanders to be aware of vehicle and or load.
- **Always** be aware of stability of vehicle and load during winching, keep others away. Alert all bystanders of an unstable condition.
- **Always** unspool as much winch rope as possible when rigging. Double line or pick distant anchor point.
- **Always** take time to use appropriate rigging techniques for a winch pull.
- **Never** touch winch rope or hook while someone else is at the control switch or during winching operation.
- **Never** engage or disengage freespool lever if winch is under load, the rope line is securing an object, winch rope is in tension or drum is moving.
- **Never** touch winch rope or hook while under tension or under load.
- **Always** stand clear of winch rope and load and keep others away while winching.
- **Never** use vehicle to pull load on winch rope. Combined load or shock load can damage, over load and break rope and winch.
- **Never** wrap winch rope back onto itself. Use a choker chain or tree trunk protector on the anchor.
- **Never** use remote when vehicle is not in line of sight of operator.
- **Never** pair more than one winch and one remote together at the same time.

> WARNING



> Moving Parts Entanglement Hazard

Failure to observe these instructions could lead to serious injury or death.

- **Always** ensure hook latch is closed and not supporting load
- **Never** apply load to hook tip or latch. Apply load only to the centre of hook.
- **Never** use a hook whose throat opening has increased, or whose tip is bent or twisted.
- **Always** use a hook with a latch.
- **Always** ensure the operator and bystanders are aware of the stability of the vehicle and/or load. Never hook back on rope.

> WARNING



> Chemical And Fire Hazard

Failure to observe these instructions could lead to serious injury or death.

- **Always** remove loose jewellery and wear eye protection.
- **Never** route electrical cables across sharp edges.
- **Never** route electrical cables near parts that get hot.
- **Never** route electrical cables through or near moving parts.
- **Always** place the supplied terminal boots on wires and terminals as directed by the installation instructions.
- **Never** lean over battery while making connections.
- **Never** route electrical cables over battery terminals. Never short batter terminals with metal objects.
- **Always** consult operator's manual for proper wiring details.
- **Always** insulate and protect all exposed wiring and electrical terminals.
- **Always** connect red(+) power cable ONLY to the positive(+) terminal of the battery.
- **Always** connect black ground(-) power cable ONLY to the negative(-)terminal of the battery.
- **Never** connect red(+) power cable to the negative(-) terminal of the battery.

> WARNING



> Falling Or Crushing Hazard

Failure to observe these instructions could lead to serious injury or death.

- **Always** stand clear, keep hands clear, keep others away.
- **Never** operate winch with less than 6 wraps of synthetic rope around the drum. Rope could come loose from the drum, as the rope attachment to the drum is not designed to hold a load.
- **Never** use winch as a hoist or to suspend a load, its a winch not a hoist.
- **Always** be certain anchor will withstand load, use appropriate rigging and take time to rig correctly.
- **Never** use winch to lift or move people.
- **Never** use excessive effort to free spool winch rope.
- **Always** use proper posture/lifting technique or get lifting assistance while handling and installing product.
- **Always** wind the winch rope on bottom (mount side) of drum.
- **Never** wind rope over top of drum.
- **Always** spool the winch rope onto the drum in the direction specified by the drum rotation labels on the winch and/or in the documentation. This is required for the automatic brake (if so equipped)to function properly.

> WARNING > CAUTION



> Cut And Burn Hazard

Failure to observe these instructions could lead to minor or moderate injury.

- Never let winch rope slip through your hands. Always use recommended gloves / hand protection.

This manual provides instructions on how to install and operate your winch and operating your Wireless Remote Control.

When installing your winch system, read and follow all mounting and safety instructions. Always use caution when working with electricity and remember to verify that no exposed electrical connections can accidentally be touched before energizing your winch circuit. For specifications and performance data, refer to the specification sheets and the RED Winches website.

> CAUTION



> Moving Parts Entanglement Hazard

Failure to observe these instructions could lead to serious injury or death.

To avoid injury to hands and fingers:

- **Never** leave winch remote control where it can be activated during free spooling, rigging, or when the winch is not being used.
- **Never** leave the wireless winch remote control turned on or connected to winch controls when installing, free spooling, rigging or servicing winch, or when the winch is not being used.

> NOTICE



AVOID WINCH AND EQUIPMENT DAMAGE

- **Always** avoid side pulls which can pile up winch rope at one end of the drum, this can damage winch rope or winch.
- **Always** ensure the freespool is fully engaged or disengaged.
- **Always** use care to not damage the vehicle frame when anchoring to a vehicle during a winching operation.
- **Never** submerge winch in water, if not IP68 rated.
- **Always** store the remote control in a protected, clean dry area.

> NOTICE



- **Never** hook the synthetic rope back onto itself because you could damage the synthetic rope .Use a strap.
- **Avoid** continuous pulls from extreme angles as this will cause the rope to pile up on one end of the drum. This can jam the rope and cause the rope to dive down through other rope layers.

COBRA 2

- > Overdrive & Standard Model Shown
- > Standard Drum Width

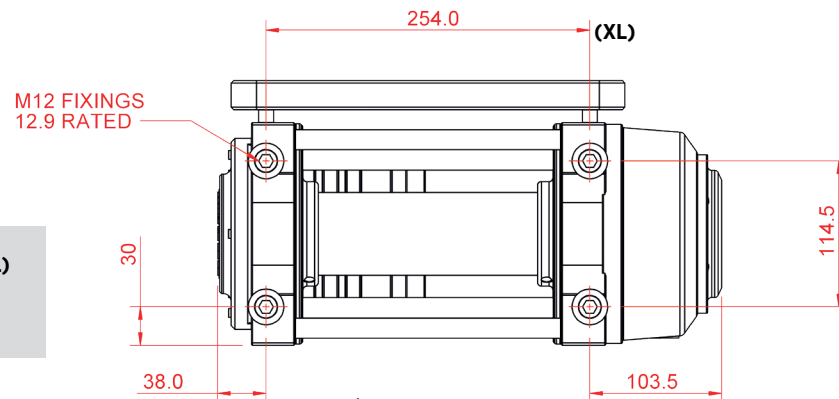
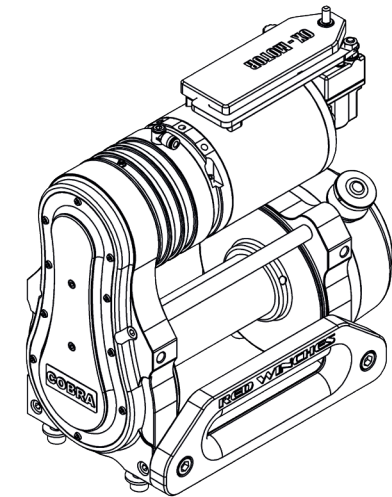
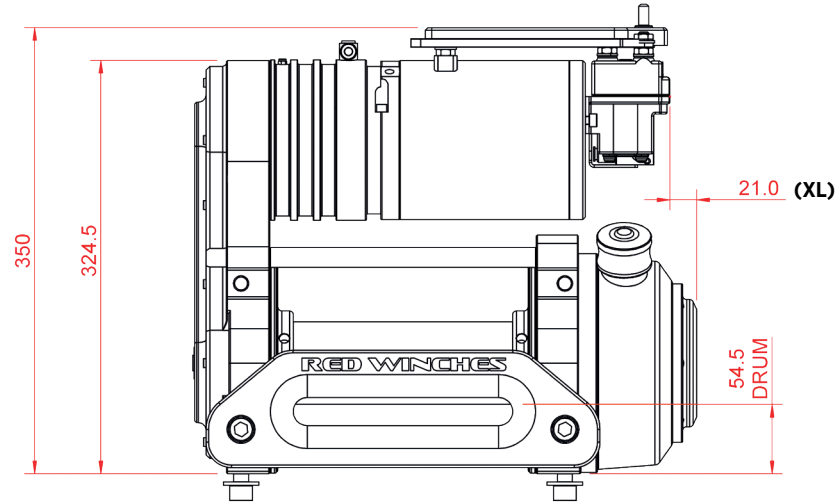
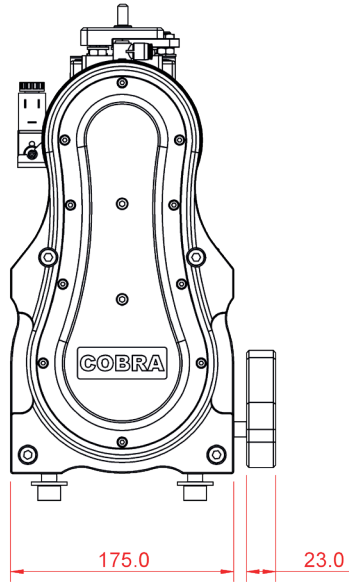
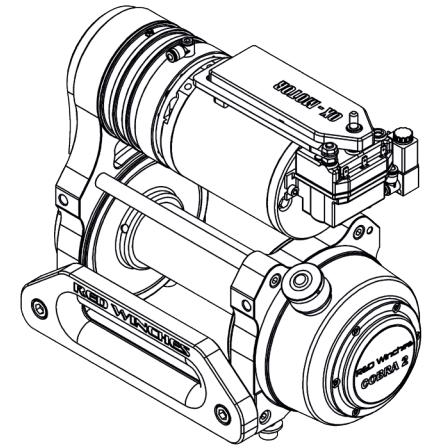
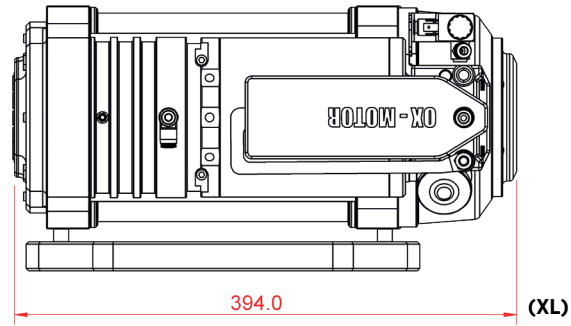

For the XL Drum versions, the dimensions marked with (XL) will increase by 76mm (3")

COBRA 2

- > Adventure Model Shown
- > Standard Drum Width

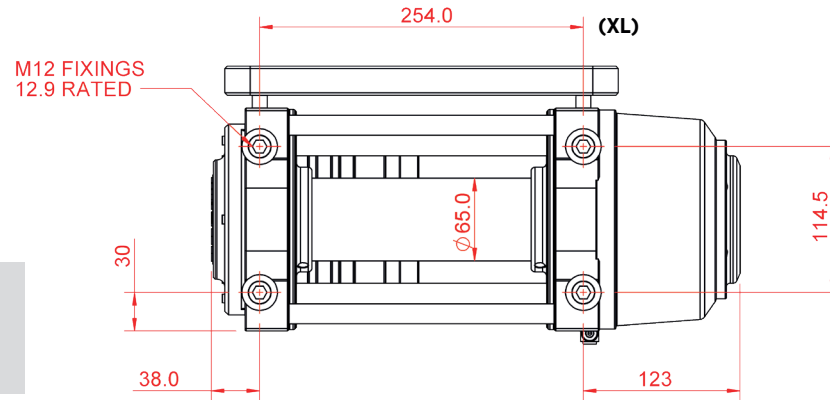
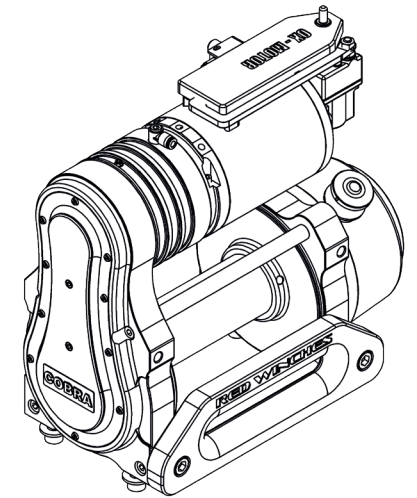
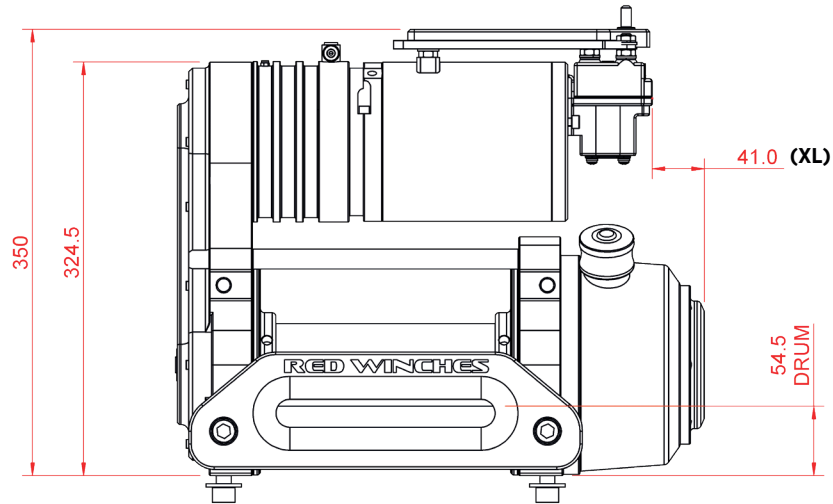
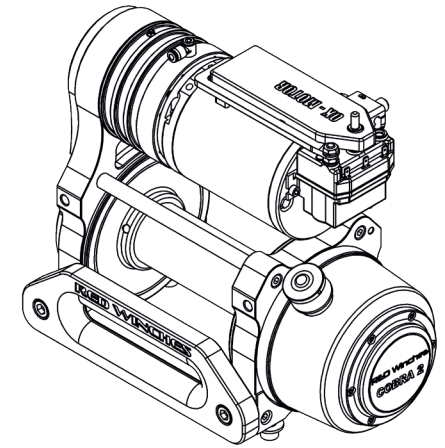
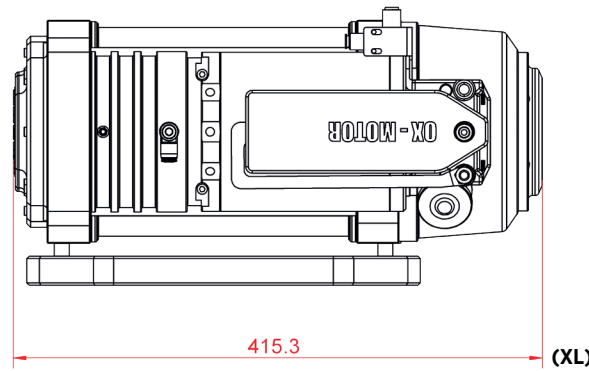
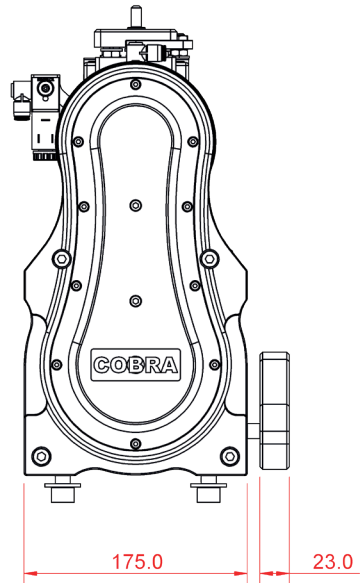

For the XL Drum versions, the dimensions marked with (XL) will increase by 76mm (3")

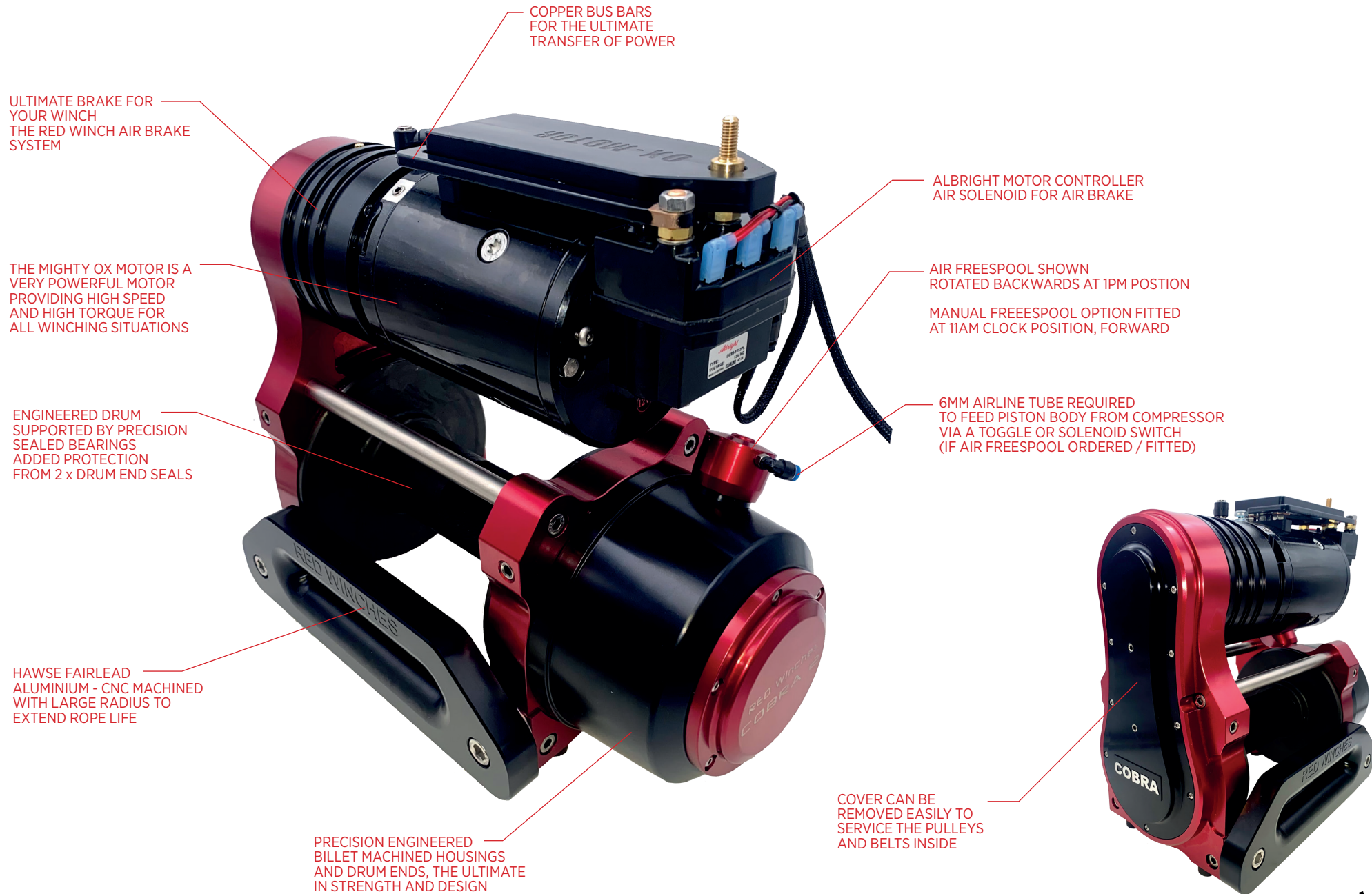

COPPER BUS BARS FOR THE ULTIMATE TRANSFER OF POWER

ULTIMATE BRAKE FOR YOUR WINCH THE RED WINCH AIR BRAKE SYSTEM

THE MIGHTY OX MOTOR IS A VERY POWERFUL MOTOR PROVIDING HIGH SPEED AND HIGH TORQUE FOR ALL WINCHING SITUATIONS

ENGINEERED DRUM SUPPORTED BY PRECISION SEALED BEARINGS ADDED PROTECTION FROM 2 x DRUM END SEALS

HAWSE FAIRLEAD ALUMINIUM - CNC MACHINED WITH LARGE RADIUS TO EXTEND ROPE LIFE

PRECISION ENGINEERED BILLET MACHINED HOUSINGS AND DRUM ENDS, THE ULTIMATE IN STRENGTH AND DESIGN

ALBRIGHT MOTOR CONTROLLER AIR SOLENOID FOR AIR BRAKE

AIR FREESPOOL SHOWN ROTATED BACKWARDS AT 1PM POSITION

MANUAL FREESPOOL OPTION FITTED AT 11AM CLOCK POSITION, FORWARD

6MM AIRLINE TUBE REQUIRED TO FEED PISTON BODY FROM COMPRESSOR VIA A TOGGLE OR SOLENOID SWITCH (IF AIR FREESPOOL ORDERED / FITTED)

COVER CAN BE REMOVED EASILY TO SERVICE THE PULLEYS AND BELTS INSIDE

COBRA 2 > Exploded Diagram

> MAIN WINCH BODY

UNLESS SPECIFIED	
FASTENER	TORQUE
M6	10 Nm
M8	24 Nm
M10	45 Nm
M12	80 Nm
M16	160 Nm
M20	200 Nm

FASTENERS

ENSURE ALL FASTENERS ARE TORQUED TO THE CORRECT VALUES. LOCTITE 234 (THREADLOCK) TO BE APPLIED ON ALL FASTENERS

ITEM 17 - MOUNTING BOLTS

M16 X 12 CAP HEADS AR FITTED FOR OUR ASSY PROCESS ONLY. THESE BOLTS ARE TO BE REMOVED PRIOR TO INSTALLATION

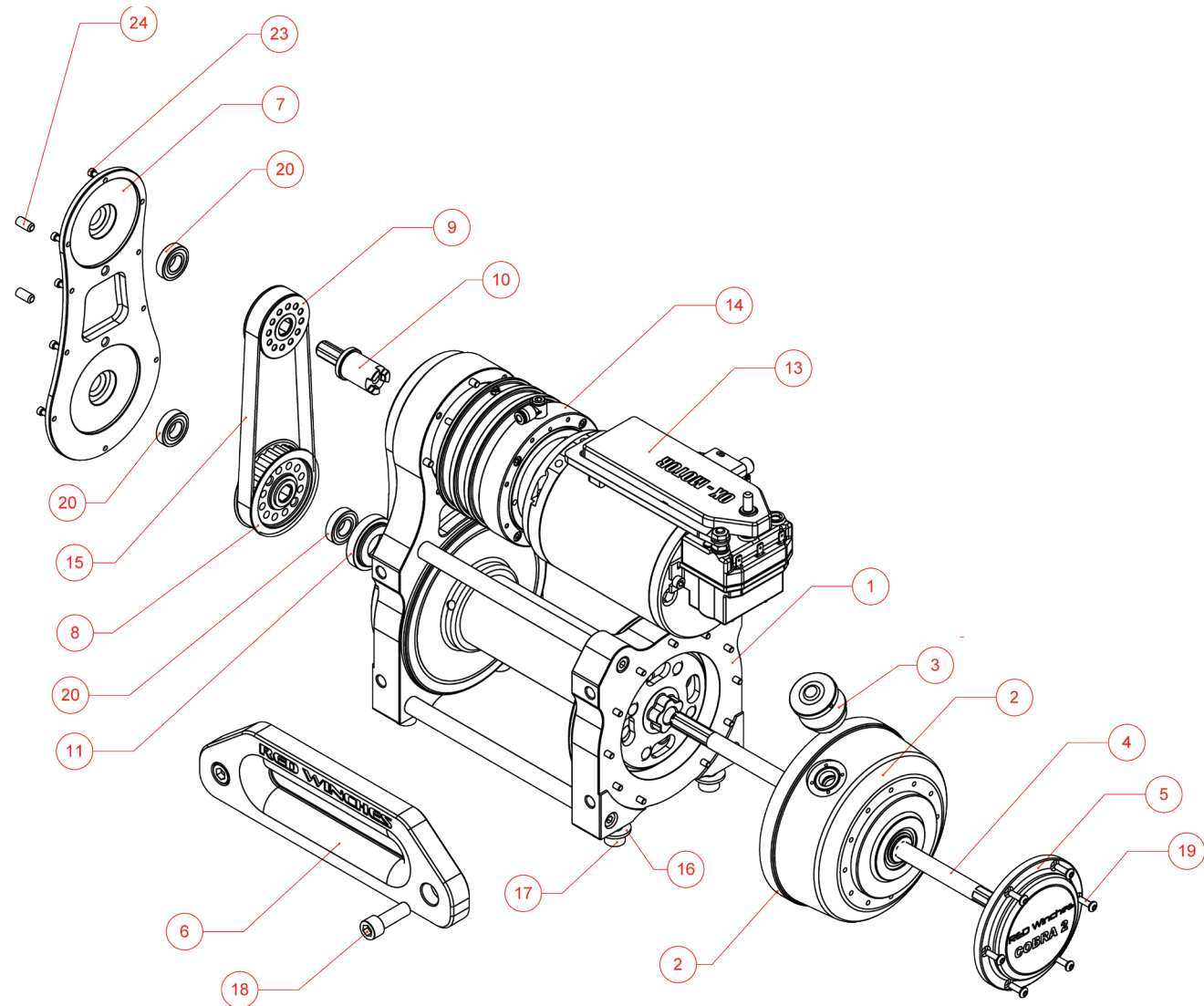

> AIR BRAKE

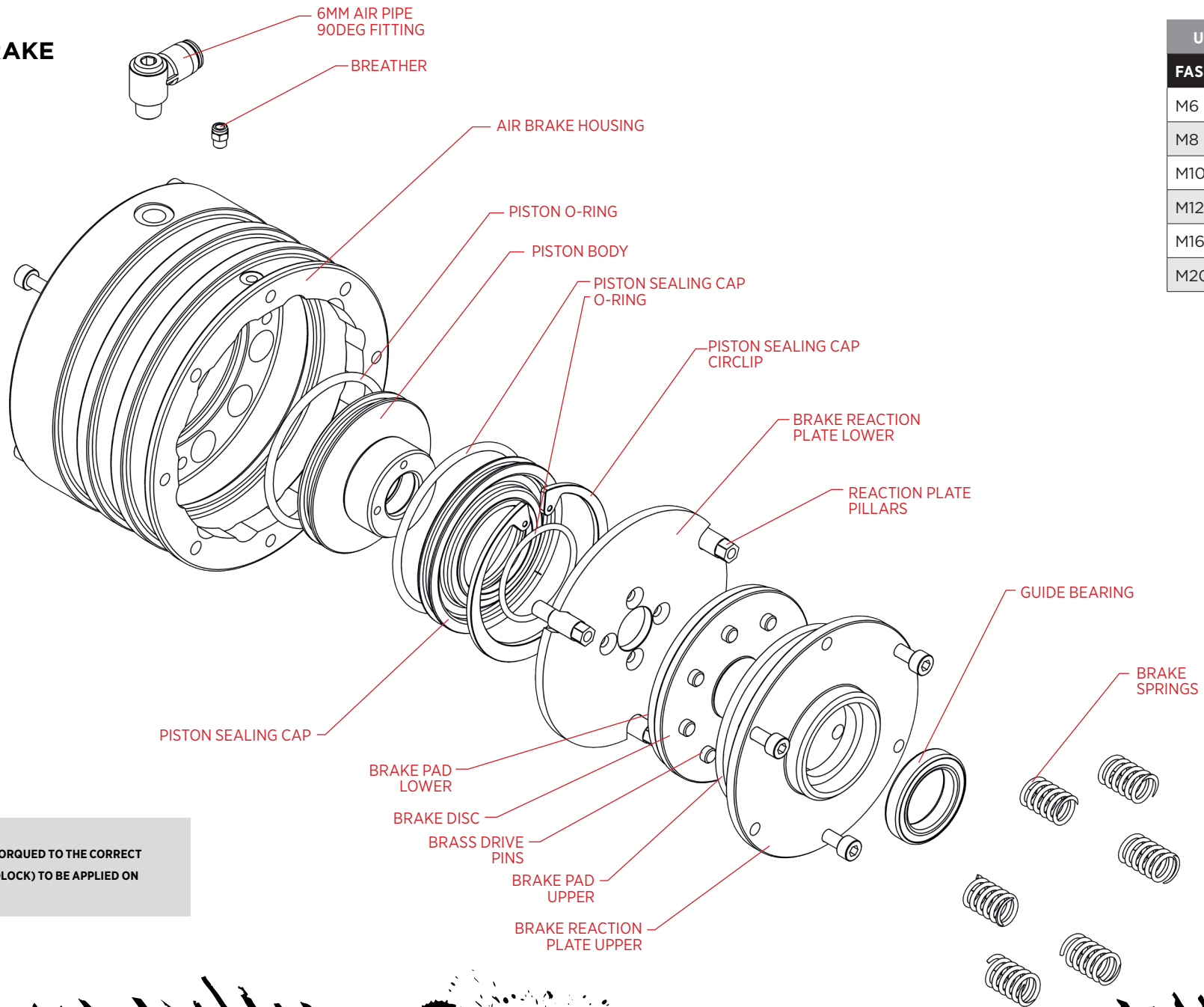

UNLESS SPECIFIED	
FASTENER	TORQUE
M6	10 Nm
M8	24 Nm
M10	45 Nm
M12	80 Nm
M16	160 Nm
M20	200 Nm

FASTENERS

ENSURE ALL FASTENERS ARE TORQUED TO THE CORRECT VALUES. LOCTITE 234 (THREADLOCK) TO BE APPLIED ON ALL FASTENERS

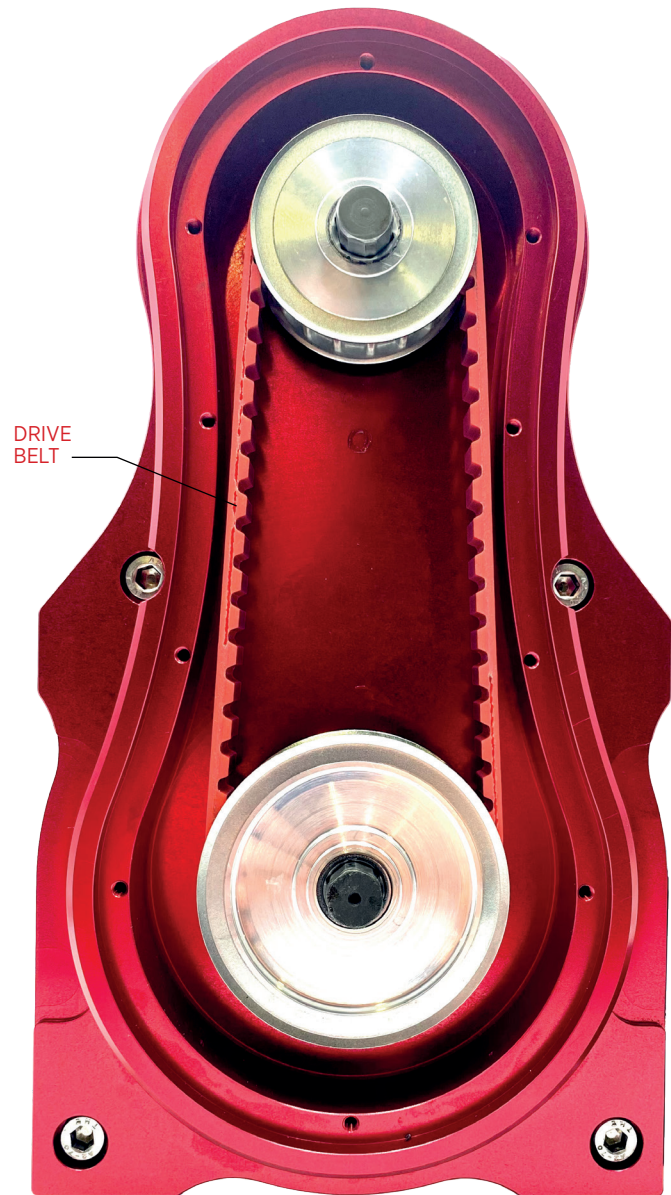

DRIVE BELT

COVER REMOVED FOR CLARITY



TOP PULLEY



LOWER PULLEY

Manual Freespool Assembly

(Not Shown)

Drum freespool:

Lift and rotate to Initiate drum freespool movement

Engage drum:

Rotate and lower

Air Freespool Assembly

(Shown)

Drum freespool:

Switch operated or wireless
Air supplied through a 2-way dc solenoid valve

Engage drum:

Remove power, air exhausts, pin re-engages

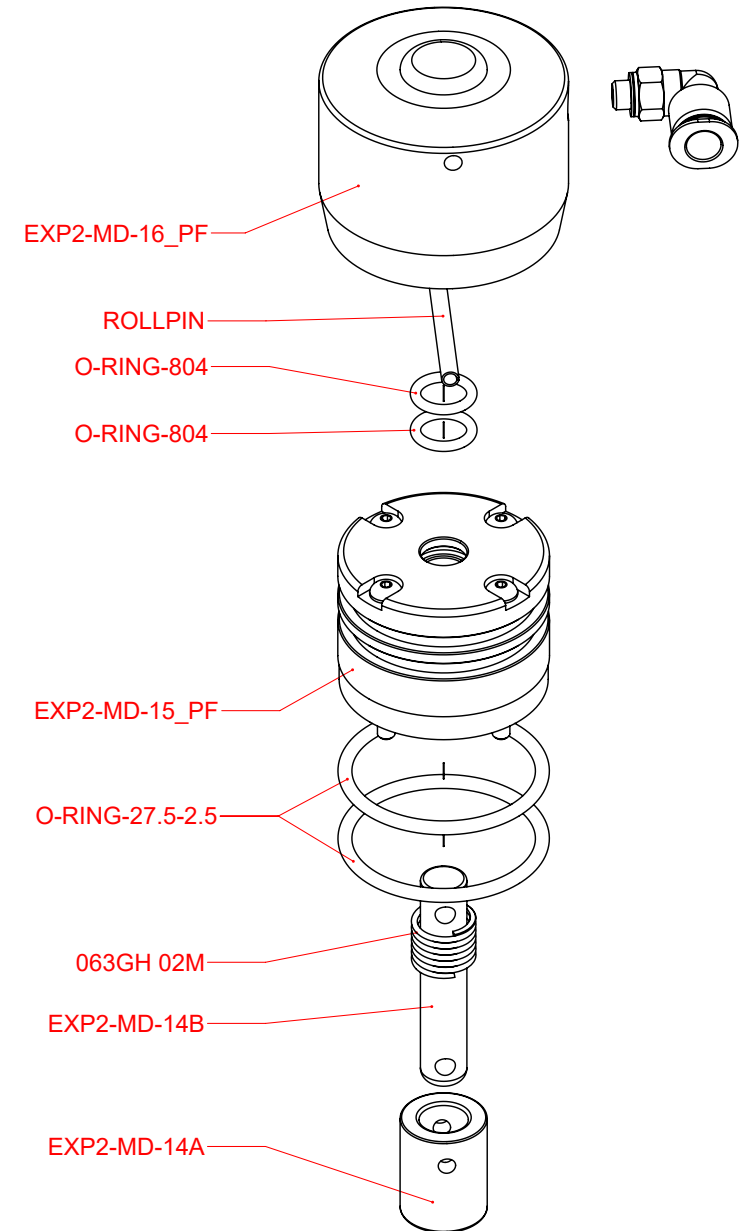
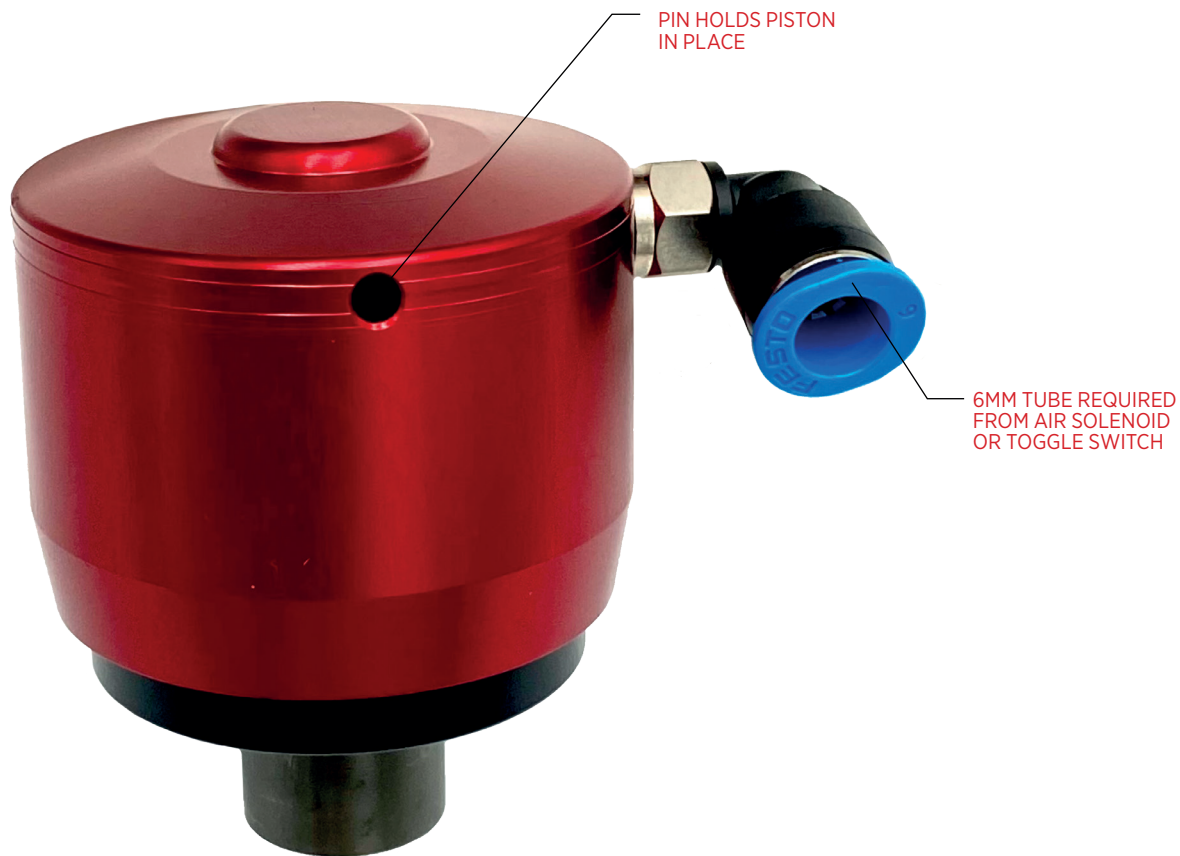

> Connection Schematic

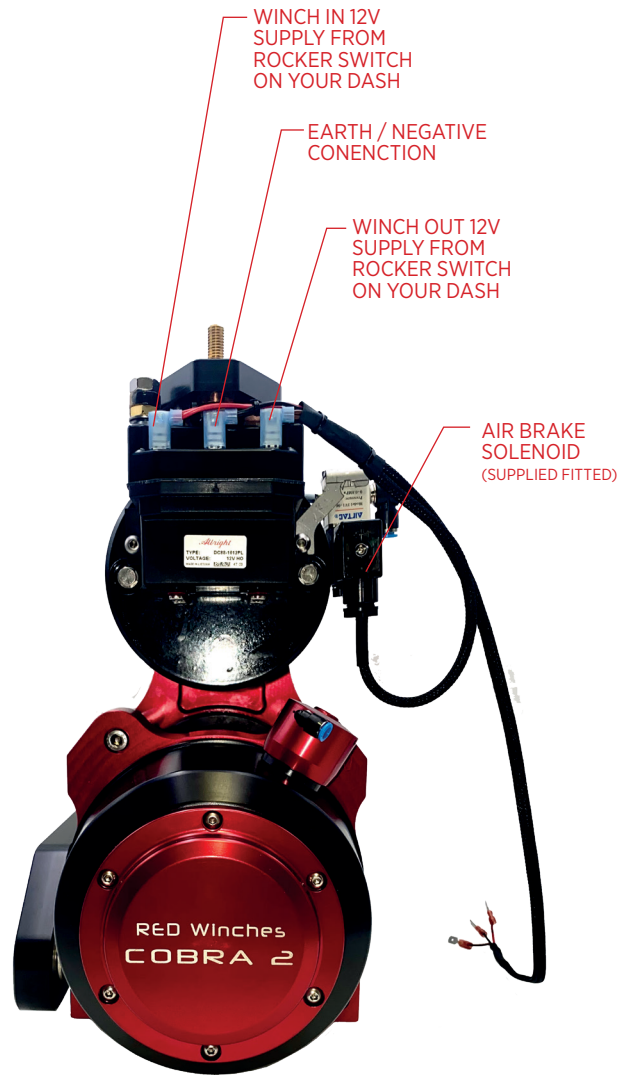

POSITIVE 12V CABLE FROM BATTERY TO BE CONNECTED HERE
M8 MALE THREAD
70mm² CABLE TO BE USED

WARNING

ENSURE POSITIVE CABLE LUG IS INSULATED FROM ACCIDENTAL TOUCHING AND DOES NOT TOUCH ANY SURROUNDING PARTS OR MOTOR BUZZ BARS

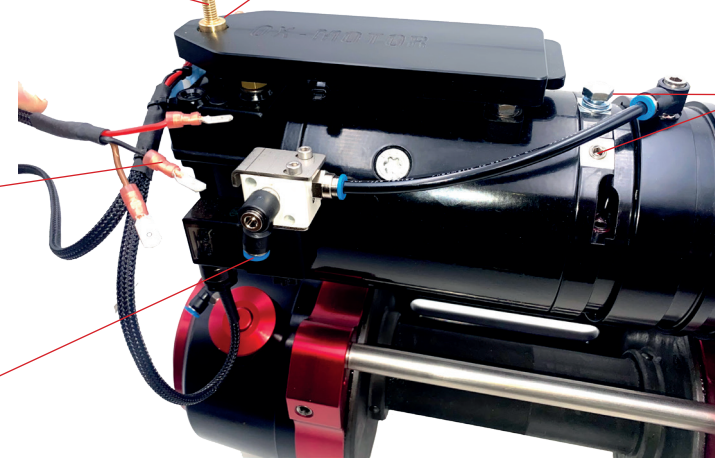

Ø6mm AIRLINE FROM ONBOARD TRUCK SYSTEM NEEDS TO BE CONNECTED HERE COMPACT ARB OR EQUIVLENT COMPRESSOR MIN AIR PRESSURE 4.5 BAR (60 PSI)

AIR BRAKE LINE Ø6mm (SUPPLIED FITTED)

AIR BRAKE FITTED AS STANDARD

OX MOTOR

12v OR 24V OPTIONS

WINCH CONTROL CABLE

DRUM FREESPOOL AIR OPERATED OR MANUAL OPERATED OPTION AVAILABLE (AIR SHOWN)

GEARBOX HOUSING

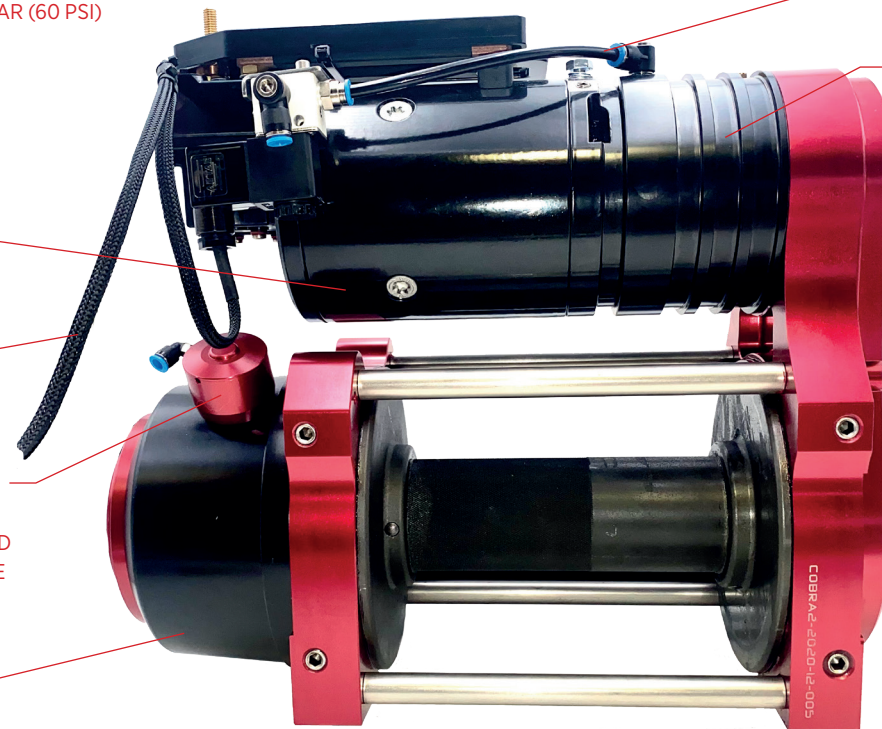

WITH THE APPROPRIATE ALTERNATOR AND BATTERY SETUP THESE OX MOTORS WILL PROVIDE HIGH SPPEED AND HIGH POWER FOR YOUR WINCH.

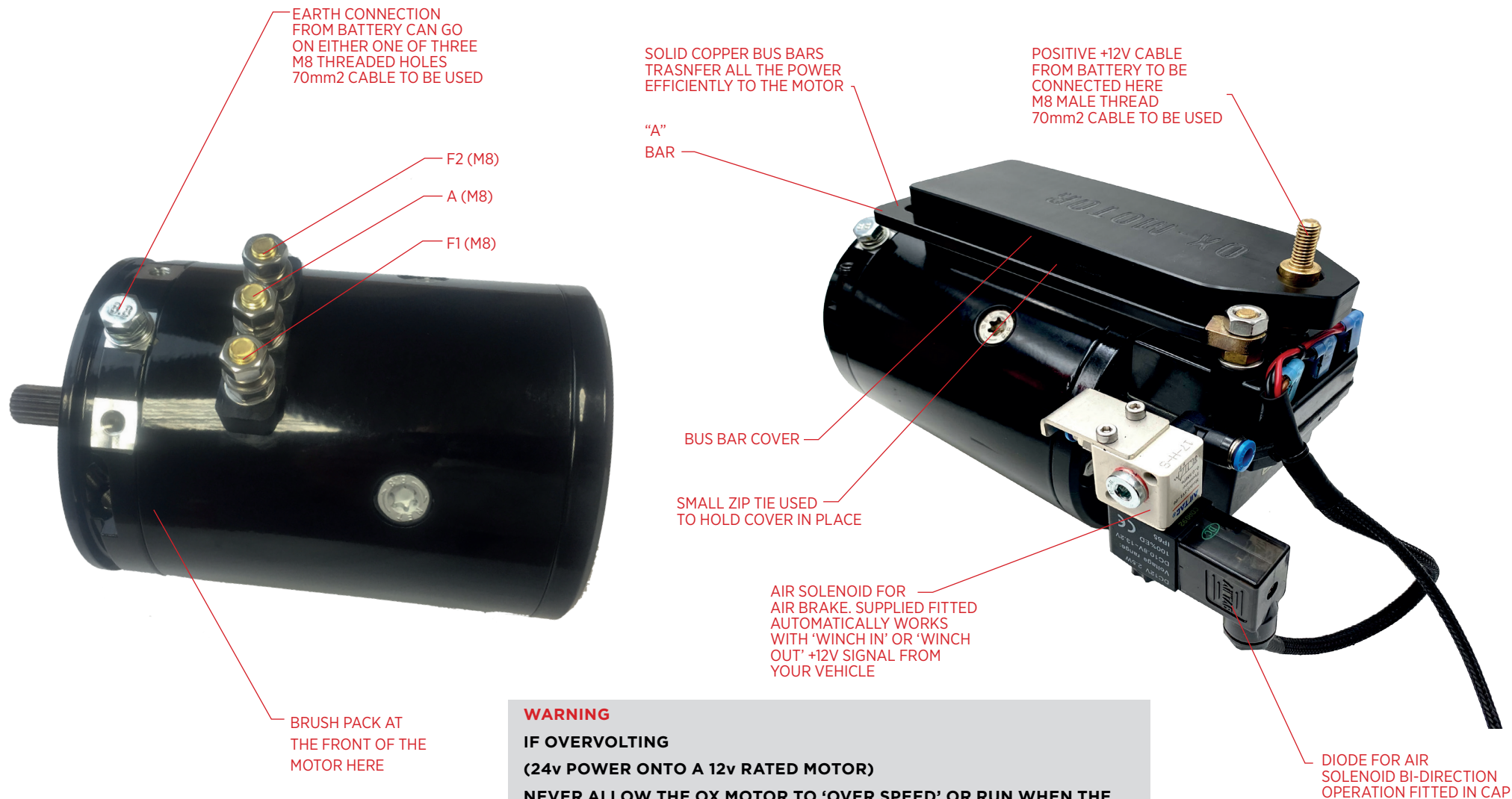

WARNING
IF OVERVOLTING
(24v POWER ONTO A 12v RATED MOTOR)
NEVER ALLOW THE OX MOTOR TO 'OVER SPEED' OR RUN WHEN THE WINCH IS NOT UNDER LOAD OR HAVE TENSION / WEIGHT IN THE WINCH LINE. THIS SITUATION CAN DAMAGE THE ARMATURE AND CAUSE THE MOTOR TO FAIL

> ADVENTURE GEARBOX

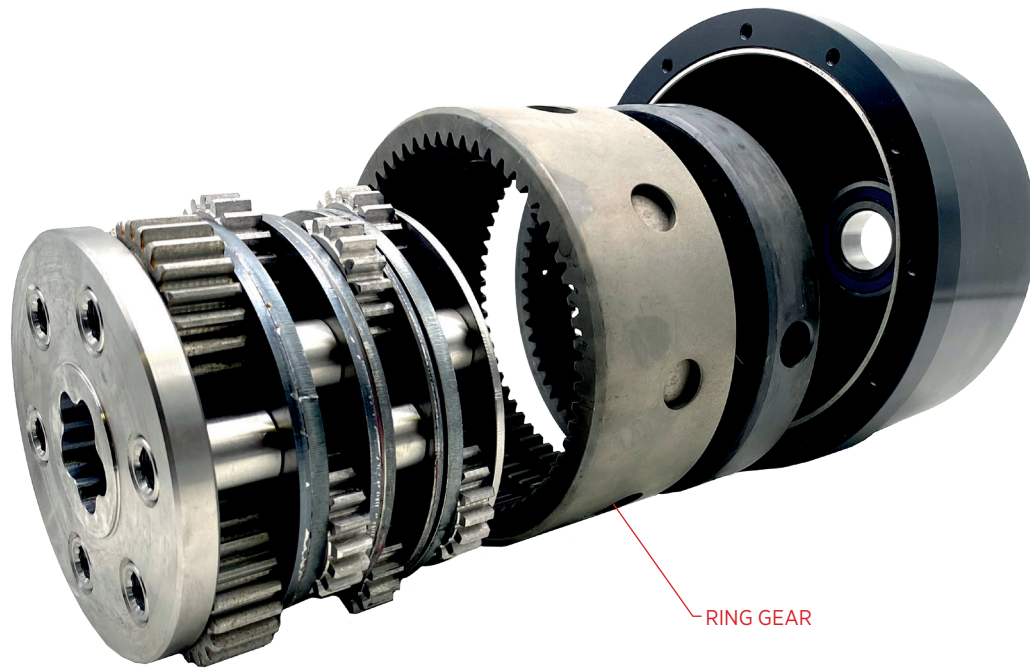

> STANDARD / OVERDRIVE GEARBOX

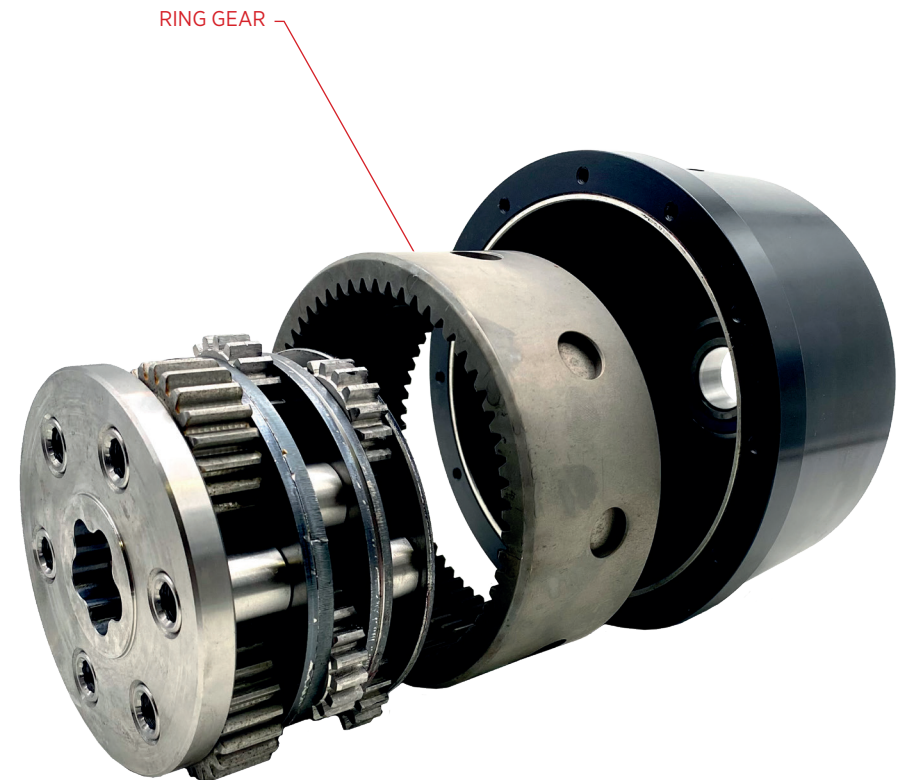

GEARBOX	RATED PULLING CAPACITY
Overdrive	2,000kg (4,400 lbs)
Standard	3,750kg (8,200 lbs)
Adventure	6,000kg (13,200 lbs)

GENERAL WINCH MAINTENANCE

> General Maintenance

- Check the battery regularly. Ensure that it is in good condition and is fully charged.
- Check that all of the connections are clean and tight. Corrosion on the battery connections can affect the performance of the winch. Ensure that the battery connections are tight.
- The winch is protected from water and rain, but avoid submerging the winch for a prolonged time, particularly if the winch casing is warm / hot.
- If it does become submerged, once clear, run the winch in and out for about 10 meters of rope to generate heat inside the winch to help dry the inside of the casing.
- Only clean your winch with soap and water, then rinse. DO NOT PRESSURE WASH THE WINCH. This can force water past the seals and gaskets.
- If you were not the last person to use the winch, always inspect the full length of the winch rope before applying any load to it.
- Have the winch serviced regularly at an authorised RED Winch centre / Partner / Distributor. (Refer to manufacturers' handbook).

> Basic Trouble Shooting

Powers in only one direction

- Faulty Solenoid, damaged remote control or remote control cable. Check remote control plug pins for damage. Check remote correctly connected.

Completely Dead

- Burned motor, poor earth, discharged battery, faulty isolator switch, damaged earth wire, damaged remote control cable or switch. Check remote control pins for damage. Check isolator switch is on. Check power is getting to the winch.

Low Power

- Check the condition of the battery and if the alternator is charging correctly, check the voltage to the battery. Are the battery terminals corroded or the cables damaged?
- Turn off any electrical items in the vehicle; Radio, lights, heated seats etc.

Winch Will Not Free Spool

- Warped mount plate, winch rope bound up on one side of the drum, bent drum flange or gear damage inside the winch.
- Check freespool air solenoid if fitted.
- Check Air solenoid or Air switch is working
- Check freespool knob is free to move and can be disengaged.

Winch Motor Gets Hot Very Quickly

- Overloaded or stalled during winching operation, Poor earth to battery, worn motor, water or mud in motor. Check the load is not heavier than the rated load. Check all connections and cables.
- Connecting power cables are too small.

Winch Brake Will Not Hold

- Worn friction material or brake overheated from extended period of powering out.
- Air solenoid controlling air brake can not exhaust (holding brake off).



**These notes are general guidelines only.
Always refer to the Manufacturers Handbook or
contact an Authorised Dealer**



OPERATION OF YOUR WINCH

A REFERENCE GUIDE
TO WINCHING



WINCH HANDLING

> Estimating Winch Loads

Before attempting to move a rolling load with a winch, an estimate of the load should be made to ensure that the safe working load limits of the winch and any supporting equipment is not exceeded.

If there is a solid resistance that prevents the load from moving, the winch must not be allowed to operate in a situation where it is overloaded; the forces and electrical loading on the vehicle this creates may become excessive. The load to be recovered must be able to move as freely as possible. Before winching it might be necessary to dig out a trapped wheel or dig away any part of the terrain upon which is resting any part of the load apart from its wheels.

There are two factors which should be added together to arrive at a total load:

The maximum inclination of the ground, even if it is only a short section; for instance a pot hole or a tree root.

On sloping ground a factor has to be allowed for the gradient as follows:

Divide the gradient angle in degrees by 60, and multiply that by the load being pulled. Therefore ascending a 30° gradient with a vehicle weighing 2,250 kg would be:

$$30^\circ / 60 = 0.5 \times 2250 = 1125 \text{ kg}$$

The pull required to move a vehicle varies depending upon the type of ground upon which it stands.

The required pull as a percentage of its weight is as follows;

Hard Surface	5%
Grass	15%
Wet Sand	15-20%
Soft Dry Sand	25-30%
Shallow Mud	35%
Bog/Marsh where chassis is not grounded	50%

A 2250kg Vehicle in shallow mud would be:

$$2250 / 100 \times 35 = 788\text{kg}$$

Therefore to calculate the true load when pulling up an incline, add the previous calculation for the gradient to the calculation for the ground condition:

Gradient 1125Kg + Ground 788kg = Total estimated load 1913Kg

The maximum operating capacity of the winch is affected by the number of wraps of rope around the drum as shown below, and consequently whenever operating a winch recovery, as much winch rope should be removed from the drum as possible to maximise mechanical advantage prior to applying the recovery load.

This example in the chart below of loads vs layers is based upon a RED Winch Cobra2:

First Layer	8000lb = 3620 kg
Second Layer	7000lb = 3175 kg
Third Layer	6000lb = 2720 kg
Fourth Layer	5000lb = 2260 kg

Please note these are maximum loads which cannot be achieved for long periods on most electric drum winches. For operations requiring periods of prolonged use, the load needs to be considerably below these figures for each layer. This helps when deciding when to use a pulley system (RED Winch Snatch Ring or Pulley Blocks) to improve the mechanical advantage of the winch.

Other types of winch e.g. mechanical or hydraulic are able to sustain maximum rated load for longer durations.

> Current Draw from Vehicle Electrical System

It is important to understand how much power is being drawn from the battery by the winch. The table below shows figures for the RED Winch Cobra2. It is important if you have a different winch you find out what the draw is from your winch and the maximum draw by the vehicle systems. A battery cannot recharge as quickly as it is discharged. Increasing the engine revs while winching, and consider increasing the revs between winches will help to maintain the charge. On most vehicles, maximum alternator output is achieved at approximately 1800 rpm. Winching without the engine running will discharge the battery rapidly and is not recommended as you will end up with a battery that can no longer start your vehicle.

LINE PULL LBS	LINE SPEED FT/ MIN	MOTOR CURRENT AMPS
0	62	47
2000	16.3	160
4000	11.8	230
6000	9.31	305
8000	7.5	370
9500	6.67	425

WINCH ROPE CARE AND INSPECTION GUIDELINES - SYNTHETIC

The life of a synthetic rope can be increased through good working practices and care. Synthetic ropes must be regularly inspected for damage. RED Winches recommend that winch ropes are always checked before use.

Under PUWER (Provision and Use of Work Equipment Regulations - UK only), work equipment should be inspected every 6 months.

Always refer to the Manufacturers Guidelines.

> Handling Guidelines

- Do not over load or shock load the rope. This can cause damage which is not visible, but could cause the rope to break later. (A shock load is a load that is 10 % greater than the recommended load, applied suddenly.)
- Do not bend the rope through an angle that is less than 6 times its diameter. (9mm x 6 = 54mm)
- Rope life can be prolonged by keeping it clean and dry.
- Do not clean ropes using a pressurised hose. (This can force abrasive material in to the fibres.) Remove rope and wash in a container of cold water. Allow the rope to dry before loading it back onto the drum.

- Synthetic ropes can be damaged by direct contact with chemicals and in some instances, the fumes from them.
- When the rope is not in use, protect it from UV light by using a winch cover.
- Synthetic rope can be weakened if exposed to heat. (Usually an overheated drum).
- Do not winch out under load if using an electric winch that has an over run brake enclosed within the winch drum.
- Where possible, do not allow the rope to come in to contact with the ground. Do not tread on the rope. This can lead to the ingress of abrasive material.
- Ropes should be marked with a unique number. A history of rope use should be kept. This should include inspection dates.

RED Winches recommends you inspect a winch rope before using it.

In all commercial applications ropes must be inspected under PUWER every 6 months. Always refer to the Manufacturers Guidelines.

- Inspect the entire length of the rope. The outer fibres of the rope will become fluffy during normal use.
- Look for areas of inconsistency. These include lumps, bumps or flat areas. These can be the result of shock loading and the rope should be destroyed.
- Damaged ropes should always be destroyed to prevent subsequent use.
- Generally if 25% or more of the fibres are broken, the rope should be destroyed.
- 12 strand ropes should be destroyed if 2 or more adjacent strands are cut.
- Rope can be damaged by direct heat, from the drum for example, or from heat caused by excessive friction. High temperatures can invisibly, reduce the strength of the rope.
- Chemical contamination can cause areas of discolouration, as can UV light. Determine the cause of the discolouration and destroy the rope if it is brittle or stiff in these areas.



> **Image 1** Rope prior to use



> **Image 2** Rope displaying 25% reduction from abrasion



> **Image 3** Full volume Rope Strand



> **Image 4** Strand reduced by 25% abrasion



> **Image 5**

Rope displays two adjacent cut strands.

This rope should be destroyed.

In an emergency, the damaged section can be removed and the rope re-spliced.

However, this should be seen as a temporary repair.

The rope should then be destroyed as soon as possible.



> **Image 6**

This rope is showing signs of compression.

If the rope is manipulated, it should return to its original state.

This should not be confused with a rope affected by heat.



> **Image 7**

This rope has been exposed to extreme heat.

Unlike the compressed rope, it will not return to its original state if manipulated.

This rope should be destroyed.

In an emergency, the damaged section can be removed and the rope re-spliced.

However, this should be seen as a temporary repair.

The rope should then be destroyed as soon as possible.

- Winches and winch equipment that are also used with wire rope should be checked for any rough or sharp areas. If any areas of this nature are found, they should be removed by sanding lightly to prevent damage to the synthetic rope.
- Assess the internal fibres of the rope, by opening it out slightly. Powdered fibre is a sign of internal wear.
- Damage to the rope can be invisible. Always keep a log of the rope's history. If you are ever in doubt about a rope's integrity, destroy it.
- Synthetic rope can be spliced together. In an emergency, it is possible to cut out a damaged area and re-splice the rope. This should only be viewed as a temporary repair, the rope should be destroyed.

WINCH ROPE CHARACTERISTICS

	Wire 8mm	Wire 9mm	Synthetic Plasma 11mm
Estimated Breaking Load	4110Kg	5753Kg	9525Kg
Factor of Safety	2:1	2:1	2:1
Safe Working Load	2055Kg	2876Kg	4762Kg

> Advantages/Disadvantages

Wire Rope	Synthetic Rope
Not affected by heat	Critical temperature 65° C Melting Point 140° C
Wire rope is heavy and can be difficult to handle	Easy to handle, lightweight, reduces sprung mass over vulnerable area over front axel
Difficult to load, if tension is released wire will "birds nest" on drum	Easy to load. Does not "birds nest".
Low priced	Expensive
Sustains little damage from abrasion	Easily affected by abrasion
Will recoil if breaks under tension	Lower level of stored energy than wire, but may still recoil violently in the event of tree strap failure while under tension.
Not affected by most solvents or chemicals	Can be affected by some solvents and chemicals
Impossible to repair successfully at full strength, strength reducing kinks	Easy to repair by splicing (In emergency only)
Wires can splinter and cause snags Does not splinter and causes snags	Does not splinter and cause snags
Wire rope must not be cross layered	Provided that no shock loads are introduced, rope can be cross layered over itself without causing damage
More resistant to mishandling	Mishandling may cause damage

A GUIDE TO WINCH LOADINGS ON A TYPICAL 4X4 VEHICLE

> Rolling Resistance Table

	1.0	1.5	2.0	2.5	3.0	3.5	4.0	4.5	5.0	5.5	6.0	6.5	7.0	7.5
Road	40	60	80	100	120	140	160	180	200	220	240	260	280	300
Grass Dry Ground	143	214	286	357	429	500	571	643	714	786	857	929	1000	1071
Grass Wet Ground	250	375	500	625	750	875	1000	1125	1250	1375	1500	1625	1750	1875
Gravel	200	300	400	500	600	700	800	900	1000	1100	1200	1300	1400	1500
Shingle	500	750	1000	1250	1500	1750	2000	2250	2500	2750	3000	3250	3500	3750
Mud	333	500	667	833	1000	1167	1333	1500	1667	1833	2000	2167	2333	2500
Wet Sticky Mud	500	750	1000	1250	1500	1750	2000	2250	2500	2750	3000	3250	3500	3750

> Vehicles Bogged Down In Mud To Casualty weight in tons 1 ton = 1000kg

	1.0	1.5	2.0	2.5	3.0	3.5	4.0	4.5	5.0	5.5	6.0	6.5	7.0	7.5
Axle	1000	1500	2000	2500	3000	3500	4000	4500	5000	5500	6000	6500	7000	7500
Wheel Tops	2000	3000	4000	5000	6000	7000	8000	9000	10000	11000	12000	13000	14000	15000
Bonnet	3000	4500	6000	7500	9000	10500	12000	13500	15000	16500	18000	19500	21000	22500

> Damage Resistance Table *This Table Is For Vehicles With Four Wheels.* Casualty Weight In Tons 1 Ton = 1000kg

No. Of Damaged Wheels	1.0	1.5	2.0	2.5	3.0	3.5	4.0	4.5	5.0	5.5	6.0	6.5	7.0	7.5
1	250	375	500	625	750	875	1000	1125	1250	1375	1500	1625	1750	1875
2	500	750	1000	1250	1500	1750	2000	2250	2500	2750	3000	3250	3500	3750
3	750	1125	1500	1875	2250	2625	3000	3375	3750	4125	4500	4875	5250	5625
4	1000	1500	2000	2500	3000	3500	4000	4500	5000	5500	6000	6500	7000	7500

> Gradient Resistance Table Casualty weight in tons 1 ton = 1000kg

Slope Degrees	1.0	1.5	2.0	2.5	3.0	3.5	4.0	4.5	5.0	5.5	6.0	6.5	7.0	7.5
10	167	250	333	417	500	583	667	750	833	917	1000	1083	1167	1250
20	333	500	667	833	1000	1167	1333	1500	1667	1833	2000	2167	2333	2500
30	500	750	1000	1250	1500	1750	2000	2250	2500	2750	3000	3250	3500	3750
40	667	1000	1333	1667	2000	2333	2667	3000	3333	3667	4000	4333	4667	5000
45	750	1125	1500	1875	2250	2625	3000	3375	3750	4125	4500	4875	5250	5625
50	833	1250	1667	2083	2500	2917	3333	3750	4167	4583	5000	5417	5833	6250
60	1000	1500	2000	2500	3000	3500	4000	4500	5000	5500	6000	6500	7000	7500

COBRA 2 - NOTES



COBRA 2 SERVICING

> Service 1

Date Of Service _____

Serial No. _____

Type of Winch _____

Signed _____

Print Name _____

> Service 2

Date Of Service _____

Serial No. _____

Type of Winch _____

Signed _____

Print Name _____

> Service 3

Date Of Service _____

Serial No. _____

Type of Winch _____

Signed _____

Print Name _____

> Service 4

Date Of Service _____

Serial No. _____

Type of Winch _____

Signed _____

Print Name _____

> Service 5

Date Of Service _____

Serial No. _____

Type of Winch _____

Signed _____

Print Name _____

> Service 6

Date Of Service _____

Serial No. _____

Type of Winch _____

Signed _____

Print Name _____



ENGINEERED TO BE BETTER



sales@red-winches.com | +44 (0)1460 297 355

RED-WINCHES.COM